

BALDWIN BOX▲LL

VIGIL *OmniCare*

combined data sheets

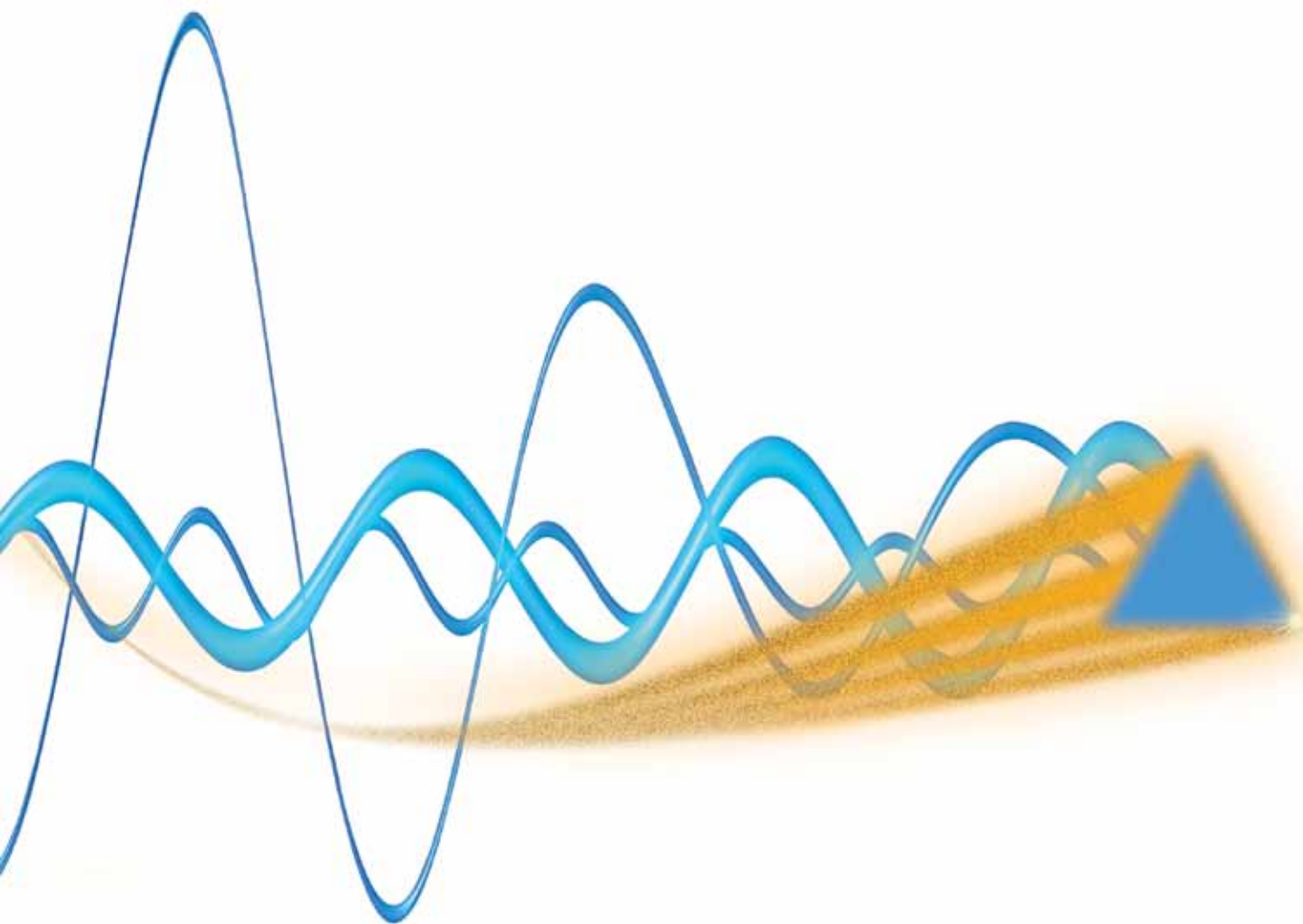

LEADING THE WAY TO SAFETY

emergency voice communication

The Disability Discrimination Act made it the responsibility of all companies, nationwide, to ensure that access to buildings and services is available to everyone - there must be no discrimination.

With access provided for all, provision must be made for safe evacuation in the event of an emergency. In some circumstances, those with physical impairments can be assisted by others - but in many situations this is not suitable or safe.

A solution comes in the form of temporary areas of safety - 'refuge areas'. The person in need of assistance is helped to the closest refuge area and awaits safe evacuation.

Refuge areas must meet certain criteria, these are covered in BS9999:2008. As well as describing suitable areas for refuge and the type of construction, the Standard specifies the need for two way communication.

Another Standard, BS5839-9:2011, provides the details on the communication system that is needed for a refuge area.

VIGIL OmniCare complies with BS5839-9:2011 and assists companies with compliance to BS9999:2008, BS8300:2009 (for the disabled toilet alarm) and the DDA.

VIGIL OmniCare:

- Disabled refuge remotes
- Fire telephones
- Advance disabled refuge remotes
- Emergency/steward telephones
- Combined fire telephones and disabled remotes
- Disabled toilet alarms
- ALL ON ONE SYSTEM

VIGIL *OmniCare*

How can VIGIL OmniCare help you?

- Loop wiring - saves up to 75% on cabling costs.
- Great flexibility - one loop for multiple styles of remote unit.
- Combined units available.
- Follow guidelines of BS5839-9:2011, BS9999:2008 and BS8300:2009.
- Satisfy the requirements of the DDA.
- Assurance of our reputation for quality and support.
- Above all - VIGIL OmniCare can help you save life!





EMERGENCY VOICE COMMUNICATIONS CONTROL PANELS

VIGIL OmniCare



OmniCare is an addressable voice communication system that allows disabled refuge, fire telephones, emergency/steward telephones and disabled toilet alarms to be connected to one master control panel. VIGIL OmniCare has been designed and built to meet BS9999:2008, BS5839-9:2011 and BS8300:2009 (for the disabled toilet alarm). Master control panels available for the system include:

BVOC4M • BVOC8M • BVOC16M • BVOC32M • BVOC48
BVOC64 • BVOC80 • BVOC96 • BVOC128

FEATURES:

- Full system monitoring.
- Battery backed for use in the event of power failure.
- Addressable via the remote unit.
- Link to fire detection system prevents hoax disabled refuge calls (toilet alarms and fire telephones remain active). Can be completely or partly overridden.
- Multiple master/slave panels can be linked in one system.
- Surface mountable - optional flush mounting with bezel.
- Lockable glazed door.
- Speech steered (disabled refuge remotes) and full duplex speech (fire telephones and emergency telephones).
- Fully monitored and battery backed (separate box to house batteries supplied with panels larger than 32-way).
- Output for unanswered call indicator; with adjustable delay. (Remote lamp/buzzer available - code BVOCCA.)
- Volt free contact - operated when in fault, set during installation.
- Indicators for: in use/occupied, call, fault, power, charger and speech volume.
- Handset volume control.
- 'Listening' facility.
- Optional stainless steel finish.
- Choice of remote units, including disabled toilet alarms.

- Remote units are connected to the master control panel in a loop configuration. (Please see separate leaflet.)
- Fully BS9999:2008, BS5839-9:2011 and BS8300:2009 compliant when installed according to the standards.

DISABLED REFUGE BREAK GLASS UNIT:

- Disabled refuge units have the option to be triggered by the fire alarm panel, so that the units become active during an emergency. (Fire telephones, emergency telephones and toilet alarms are constantly active).
- This prevents accidental or deliberate misuse as the remote units remain dormant until activated.
- In order to activate the system for non-emergency use it is necessary to override the fire panel. This is achieved by connecting a 'break glass' unit (BVCRBG) to the master control panel.
- Enables weekly testing and routine maintenance - as set out in BS5839-9:2011.

REMOTE LAMP & BUZZER (BVOCCA):

- For areas where master console is not manned permanently.
- Indicates a call to master control panel.
- Single gang unit with red LED, sounder and buzzer mute.
- Stainless steel finish.
- Settings to allow call delay of up to one second (carried out at master console).
- Two core cable (non fire rated) to master console required.

OMNICARE MASTER CONTROL PANEL SPECIFICATION:

	4 to 32-way	48 to 64-way	80 to 127-way
Power supply	230V AC		
Power consumption (VA)	10VA + 1VA per remote handset fitted		
Humidity range	95% non-condensing		
Temperature range	-10°C to +30°C		
Indicators	In use, call, fault, power, charger and speech volume		
Remote signalling of fault	Volt-free contact, closing/opening (set on commissioning)		
Dimensions mm W x H x D	410 x 290 x 200	410 x 455 x 200	410 x 777 x 200
Bezel dimensions mm W x H (radius)	461 x 340 (25)	461 x 506 (25)	461 x 827 (25)
Bezel cut out mm	420 x 300	420 x 465	420 x 787
Knockouts/cable entry points	20mm diameter top & rear		
Mounting position	Vertical centre of controls should be at a height of 1.4-1.5m (BS5839-9)		

SYSTEM REQUIREMENTS:

- Fire rated enhanced four core, colour coded, cable with a screen must be used for fire fighting systems.
- Standard fire resisting cables could be considered suitable for:
 - EVC systems for use in disabled refuges but not for fire-fighting in (a) sprinklered buildings; (b) unsprinklered buildings less than 30m in height, provided that evacuation takes place in three or fewer phases.
 - Underground sections of cabling at sports and similar venues.
- Up to 200m cable run between remote units and master control panel as standard.
- A repeater unit (BVFREPEM) must be used if distance between remotes exceeds 200m.
- Disabled refuge, advance disabled refuge, fire telephone, emergency/steward telephone, combined DRS/fire telephone and toilet alarm units can be placed on the same loop.
- A ring circuit configuration must be used to wire the remote units. Typically 20-30 remotes per loop.
- Repeater units (BVFREPEM) are used to connect the toilet alarms to the system.

PERMANENT, SELF-ADHESIVE VINYL LABELS:



BVOCLAB2

A BVOCLAB2 is supplied with each OmniCare master panel.



BVOCLAB1



BVOCLAB3

BALDWIN BOXALL

TEL: +44 (0) 1892 664422
FAX: +44 (0) 1892 663146

EMAIL: MAIL@BALDWINBOXALL.CO.UK
WEB: WWW.BALDWINBOXALL.CO.UK

BALDWIN BOXALL COMMUNICATIONS LTD
WEALDEN INDUSTRIAL ESTATE,
FARNINGHAM ROAD, CROWBOROUGH,
EAST SUSSEX, TN6 2JR, UNITED KINGDOM.



WE RESERVE THE RIGHT TO CHANGE THE PRODUCT SPECIFICATION WITHOUT PRIOR NOTICE OR LIABILITY. DOC NO: 1.0010.0911



EMERGENCY VOICE COMMUNICATIONS OMNICARE REMOTES

VIGIL *OmniCare*

OmniCare is an addressable emergency voice communication (EVC) system that allows disabled refuge, fire telephones, emergency/steward telephones and disabled toilet alarms to be connected to one master control panel. VIGIL OmniCare has been designed and built to meet BS9999:2008, BS5839-9:2011 and BS8300:2009 (for the disabled toilet alarm). Remote units available include:

- disabled refuge
- fire telephone
- advance disabled refuge
- combined disabled refuge & fire telephone
- emergency/steward telephone
- disabled toilet alarm

FEATURES:

- Speech steered (disabled refuge remotes) - full duplex speech (fire and emergency/steward telephones).
- Self-powered from ring circuit (except toilet alarm).

Disabled refuge remote:

- Green or stainless steel finish.
- Volt free contact, active when occupied. To operate over-door lamps, silence speaker/sounder, etc.
- Call button.
- Option to be permanently 'active' if required.
- Reset from either remote (key switch) or master control panel.
- Surface mountable (optional flush mount bezel available).

Advance disabled refuge remote:

- Green finish.
- Induction loop, Braille, tactile and luminiscent text.
- Volt free contact, active when occupied. To operate over-door lamps, silence speaker/sounder, etc.
- Call button.
- Surface or flush mount versions available.
- Option to be permanently 'active' if required.
- Reset via button push or master control panel.

Fire telephone:

- Red or stainless steel finish.
- Rugged red handset with hearing aid compatible earpiece and loudspeaker.
- Hands free use.
- Door latch initiates call.

- Push catch or slot lockable door and/or beacon.
- Conference facility (via master control panel).
- Surface mountable (optional flush mount bezel available).

Emergency/steward telephone:

- Same features as 'fire telephone' except green finish.

Combined disabled refuge/fire telephone:

- Same features as 'disabled refuge' and 'fire telephone'.

Disabled toilet alarm:

- Connected to master control panel via 'repeater unit' (product code BVFREPEM).
- Fully compliant to BS8300:2009.

OTHER PRODUCTS AVAILABLE:

IP66 rated DRS enclosure:

- Surface mounting, green IP66 rated enclosure to house standard disabled refuge remote. (Product code BVCRIPBG).
- Termination card is included for simple install.
- Dimensions 200mm (W) x 200mm (W) x 80 mm (D).

Plasterboard backbox:

- Enables the mounting of standard disabled refuge remotes in stud partition walls.
- Steel construction and supplied with either a green or stainless steel bezel. (BVCRFBG/S).
- Termination card is included for simple install.
- 20mm knock outs top and bottom for cable entry.
- Dimensions 131mm (W) x 142mm (H) x 65mm (D).
- Requires a cut out of 134mm (W) x 150mm (H).

OMNICARE REMOTES SPECIFICATION:

	Disabled refuge (DRS)	Advance disabled refuge	Fire telephone	Emergency / steward telephone	Combined DRS and fire telephone
Product code - BVOC...	ECPG/ECPS	AS/AF	F/FB/FL/FLB/FS/FSL	ET/ETB/ETL/ETLB	C/CB/CL/CLB/CSP/CSL
Power supply	12-40V DC self powered from ring circuit				
Power consumption	30mA @ 35V typical				35mA @ 35V typ.
Weight	1kg	1kg	4kg	4kg	4.5kg
Humidity range	95% non-condensing				
Temperature range	-10°C to +40°C				
Indicators	System healthy, status	System healthy, system activated, in use	System healthy	System healthy	System healthy, call status
Finish	Green or stainless steel	Green with Braille and tactile/ luminescent text	Red or stainless steel	Green	Red or stainless steel
Dimensions mm WxHxD	134x134x56	flush: 178x440x3 surface: 180x440x64	130x350x100	130x350x100	130x480x100
Bezel dimensions mm WxH (radius)	154x154x(10)		170x390x(20)	170x390x(20)	170x520
Bezel cut out mm WxH	136x136		138x358	138x358	138x488
Flush mount cut out mm WxH		133x235x65			
Knockouts/cable entry points	7 (20mm & 26mm)	20mm & 25mm	20mm & 25mm	20mm & 25mm	20mm* & 25mm
Mounting position	Remotes should be placed at a height of 1.3-1.4m, OR in refuge areas: at a height of 900mm to 1.2m				

* 2 x 20mm top (site wiring), and
2 x 20mm bottom (relay contacts from disabled refuge section).

SYSTEM REQUIREMENTS:

- Fire rated enhanced four core, colour coded, cable with a screen must be used for fire fighting systems.
- Standard fire resisting cables could be considered suitable for:
 - EVC systems for use in disabled refuges but not for fire-fighting in (a) sprinklered buildings; (b) unsprinklered buildings less than 30m in height, provided that evacuation takes place in three or fewer phases.
 - Underground sections of cabling at sports and similar venues.
- Up to 200m cable run between remote units and master control

panel as standard.

- A repeater unit (BVFREPEM) must be used if distance between remotes exceeds 200m.
- Disabled refuge, advance disabled refuge, fire telephone, emergency/steward telephone, combined DRS/fire telephone and toilet alarm units can be placed on the same loop.
- A ring circuit configuration must be used to wire the remote units. Typically 20-30 remotes per loop.
- Repeater units (BVFREPEM) are used to connect the toilet alarms to the system.

BALDWIN BOXALL

TEL: +44 (0) 1892 664422
FAX: +44 (0) 1892 663146

EMAIL: MAIL@BALDWINBOXALL.CO.UK
WEB: WWW.BALDWINBOXALL.CO.UK

BALDWIN BOXALL COMMUNICATIONS LTD
WEALDEN INDUSTRIAL ESTATE,
FARNINGHAM ROAD, CROWBOROUGH,
EAST SUSSEX, TN6 2JR, UNITED KINGDOM.



WE RESERVE THE RIGHT TO CHANGE THE PRODUCT SPECIFICATION WITHOUT PRIOR NOTICE OR LIABILITY. DOC NO. 1.0011.09/11



EMERGENCY VOICE COMMUNICATIONS

OMNICARE REMOTES

DISABLED TOILET ALARM

VIGIL OmniCare

The Baldwin Boxall disabled toilet alarm is fully compliant to BS8300:2009. The British Standard requires all new disabled toilets to be fitted with an emergency toilet alarm. Our system provides a compliant, reliable and easy to use disabled persons toilet alarm. Products available in the range:

BVOCDTA • BVOCDTAS • BVOCDTAS2 • BVOCSSS • CRP • CRPS

IN THE KIT:

Controller:

Combined power supply and controller with reset/call acknowledge button, audible alarm and high visibility LED. (The 'call acknowledge' feature is set during installation.)

Pull switch:

Ceiling mounted pull cord (with two fully compliant 'G' pulls) and LED.

Reset point:

Reset button and LED to reset calls locally.

Light/sounder:

Over-door triangular lens with integral sounder to attract attention.

SYSTEM FEATURES:

- The disabled toilet alarm kit can be fitted as a component of the OmniCare EVC system or as a completely independent, stand-alone toilet alarm.
- Disabled toilet alarm units are connected to the VIGIL OmniCare system via a BVFREPEM repeater unit.
- Any number of disabled toilet alarms can be wired to each repeater (will show as one call point on master panel).
- Fully conforms to BS8300:2009 requirements.
- Call acknowledge feature (when enabled). Pressing the controller's 'reset' button acknowledges a call and changes the tone emitted by the over-door light/sounder. After 120 seconds the call reverts back to original alarm status.*

* This feature is not currently available from an Omnicare master panel.

- Integral power supply - requires mains power.
- Monitored battery backup.
- Powerful LEDs and sounder.
- 'Supply' and 'battery healthy' indicators.
- Two alarm modes (flashing or steady LEDs).
- Reset button enable/disable.
- Self test facility to ensure all sounders and LEDs are fully operational.
- Plug on terminals to ease installation.
- Supplied with disabled WC door sign.
- Up to three ring pulls can be fitted per 'station'.

PRODUCTS:

- BVOCDTA - disabled toilet alarm kit - white.
- BVOCDTAS - disabled toilet alarm kit - with stainless steel overdoor light and reset point.
- BVOCDTAS2 - disabled toilet alarm kit - all components in stainless steel.
- BVOCSSS - additional pull cord - white.
- BVOCSSS2 - additional pull cord - stainless steel.
- CRP - slave reset point - white.
- CRPS - slave reset point - stainless steel.

DISABLED TOILET ALARM KIT SPECIFICATION:

	Controller	Over-door light / sounder	Reset point	Ring pull (white)	Ring pull (stainless steel)
Power supply	220-240V AC				
Output	12V DC				
Fuse	Internal thermal				
Alarm type	90dB @ 30cm				
Battery backup	Alkaline - type A23 12V				
Dimensions mm WxHxD	85x145x13	85x85x13	85x85x13	30x80 (diameter)	85x85x18
Cable requirements	4 or 6 core security alarm cable 7/0.2 or similar				
Back box requirements (not supplied)	35mm deep double gang, flush back box or 'round cornered' surface box	25mm deep single gang flush back box or 'round cornered' plastic surface box		Supplied with its own surface mount enclosure	25mm deep single gang flush back box or 'round cornered' surface box

ALTERNATIVE PRODUCT OPTION - CallCare:

For systems requiring multiple call points including warden/nurse calling, panic alarms, toilet/bathroom alarms, etc, please refer to our leaflet on CallCare.

Please note:

The disabled toilet alarm provides a visual and audible alert at the main console, speech communication is not possible.

The toilet alarm kits featured on this sheet are NOT compatible with CallCare products. (Please contact our sales department who will be happy to provide assistance with your specification.)

BALDWIN BOX▲LL

TEL: +44 (0) 1892 664422
FAX: +44 (0) 1892 663146

EMAIL: MAIL@BALDWINBOXALL.CO.UK
WEB: WWW.BALDWINBOXALL.CO.UK

BALDWIN BOXALL COMMUNICATIONS LTD
WEALDEN INDUSTRIAL ESTATE,
FARNINGHAM ROAD, CROWBOROUGH,
EAST SUSSEX, TN6 2JR, UNITED KINGDOM.



WE RESERVE THE RIGHT TO CHANGE THE PRODUCT SPECIFICATION WITHOUT PRIOR NOTICE OR LIABILITY. DOC NO. 1.0012.011

BALDWIN BOX▲LL

LEADING THE WAY TO SAFETY



EMERGENCY VOICE COMMUNICATIONS

OMNICARE TOUCHSCREEN CONTROL

VIGIL *OmniCare*

OmniCare is an addressable voice communication system that allows disabled refuge, fire telephones, emergency/steward telephones and disabled toilet alarms to be connected to one master panel. Touchscreen control adds further flexibility to the system. Products in the range:

BVOCTSB • BVOCTSG • BVOCTSHS • BVOCTSNB • BVOCTSNG
BVOCTSHN • BVOCTSIF • BVOCTSCI6 • BVOCTSC32 • BVOCTSC48

FEATURES:

- Each system is bespoke, designed specifically for the system it is intended. There are two screen display options: 'button' or 'graphic layout' view.
- Can be installed remotely from the master panel, providing a stylish option for reception/lobby areas.
- Suitable for single panel or networked systems.
- Simple to navigate touchscreen control.
- 'Administrator' and 'guest' password protected accounts.
- Displays the condition of each zone:
 - Standby (no current activity).
 - Calling.
 - Occupied.
- Replicates the status of the master control panel.
- Provides the operator with complete control of the OmniCare system.
- PC will emit sound to mimic activity at master panel.
- History and fault log with realtime date stamp. Enables administrators to view activity and response times on the system.
- State-of-the art high performance computer and screen all in one.
- High resolution LCD display with fingertip touch sensitivity.
- Connection to the OmniCare panel can be via RS232, RS485 or Ethernet. Providing plenty of options for installers.
- Please note: a master control panel must be installed on the system - which is fully compliant to BS5839-9.

SYSTEM COMPONENTS:

Single panel systems:

(Master panel can be any from OmniCare range.)

- BVOCTSB:** All-in-one 23" touchscreen PC with button graphics. (Install within 10m of master panel. Greater distances possible, please contact our sales department if this is required.)
- BVOCTSG:** As above with full graphic layout of the system.
- BVOCTSHS:** Red telephone handset (desktop) with interface for touchscreen. Enables speech communication between the remote units on the system and the touchscreen operator.

Multi-panel networked systems:

(Special master panels, see below.)

- BVOCTSNB:** All-in-one 23" touchscreen PC with button graphics.
- BVOCTSNG:** As above with full graphic layout of the system.
- BVOCTSHN:** Red telephone handset (desktop) with interface for touchscreen. Enables speech communication between the remote units on the system and the touchscreen operator.
- BVOCTSIF:** Interface rack. Includes interface for copper network cabling and BVRD2M4 EVAS routeing matrix. (Install within 3m of touchscreen. Greater distances possible, please contact our sales department if this is required.)
- BVOCTSCI6:** 16-way master panel.
- BVOCTSC32:** 32-way master panel.
- BVOCTSC48:** 48-way master panel.

EXAMPLE OF NETWORKED SYSTEM:

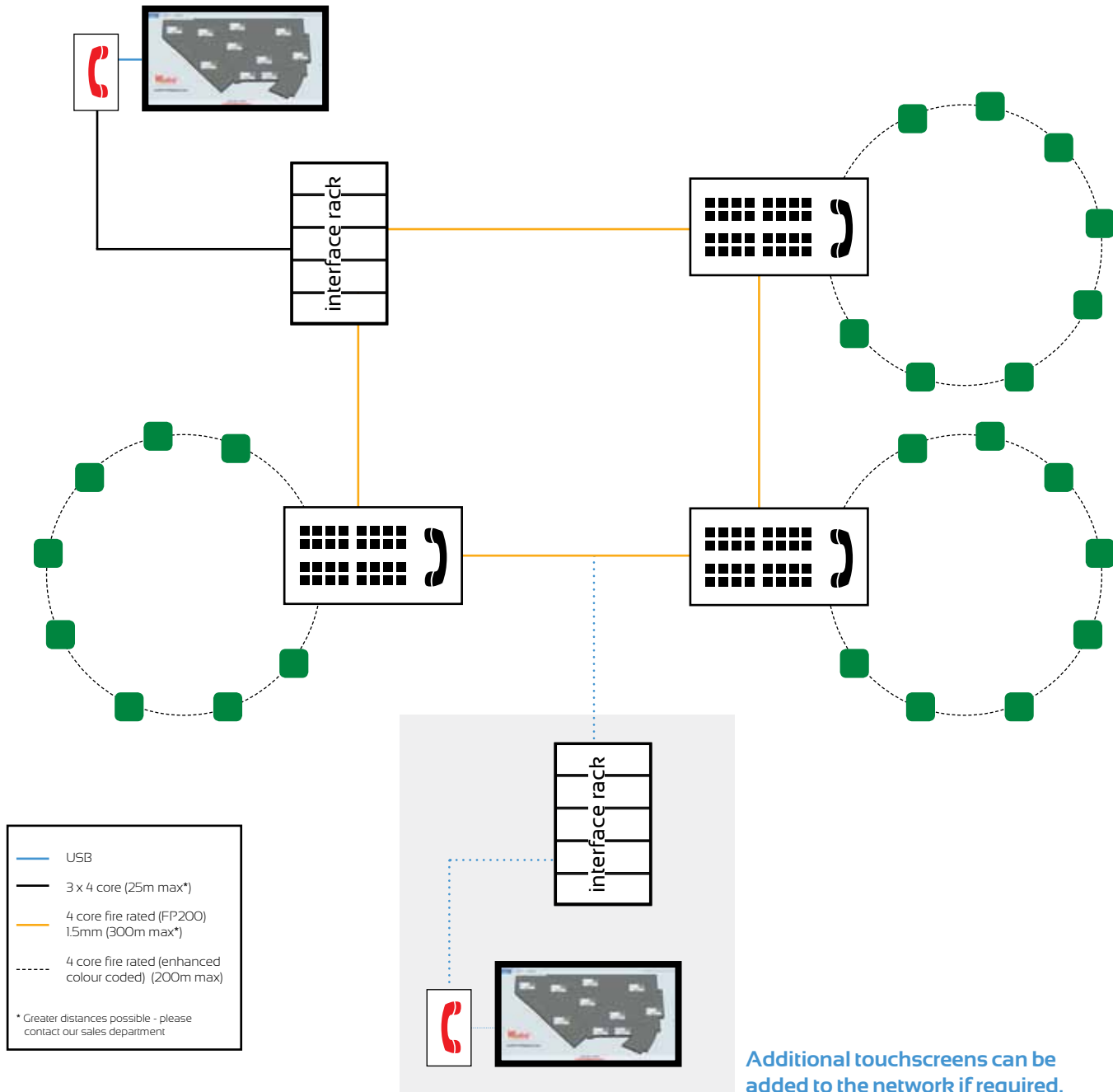

BALDWIN BOXALL

TEL: +44 (0) 1892 664422
 FAX: +44 (0) 1892 663146

EMAIL: MAIL@BALDWINBOXALL.CO.UK
 WEB: WWW.BALDWINBOXALL.CO.UK

BALDWIN BOXALL COMMUNICATIONS LTD
 WEALDEN INDUSTRIAL ESTATE,
 FARNINGHAM ROAD, CROWBOROUGH,
 EAST SUSSEX, TN6 2JR, UNITED KINGDOM.



WE RESERVE THE RIGHT TO CHANGE THE PRODUCT SPECIFICATION WITHOUT PRIOR NOTICE OR LIABILITY. DOC NO: 1004207/1



EMERGENCY VOICE COMMUNICATIONS CABLING & NETWORKING

VIGIL OmniCare



OmniCare is an emergency voice communication system that allows disabled refuge, fire telephones, emergency/steward telephones and disabled toilet alarms to be connected to one master control panel. VIGIL OmniCare has been designed and built to meet BS9999:2008, BS5839-9:2011 and BS8300:2009 (for the disabled toilet alarm).

GENERAL INFORMATION:

- There are two main components - the master control panel(s) and the remote units.
- Remote units are wired in a ring circuit configuration and are 'self-learning', with an auto-commissioning feature.
- The system utilises enhanced four-core cable plus screen ring circuit technology to allow continued operation in the event of a cable break.
- Any combination of remote units can be linked to the control panel on a single wiring loop.
- The master control panel is typically wall mounted in a central control room.
- Remote units are wall mounted in locations such as refuge areas, stairwells, fallback positions, corridors and other 'gathering' points, at a height easily reached by users (see 'MOUNTING POSITION').
- More than one master panel can be placed on the ring circuit, thus allowing control of local areas.
- Up to 200m cable run between remote units and master control panel as standard.
- A repeater unit (BVFREPEM) must be used if distance between remotes exceeds 200m.
- Disabled refuge, advance disabled refuge, fire telephone, emergency/steward telephone, combined DRS/fire telephone and toilet alarm units can be placed on the same loop.
- Typically 20-30 remotes per loop.
- Repeater units (BVFREPEM) are used to connect the toilet alarms to the system.

MOUNTING POSITION - BS5839-9:2011 RECOMMENDS:

- The master control panel should have its vertical centre of controls mounted at a height of 1.4-1.5m.
- The master control panel should be installed in an area of low fire risk.
- Outstations should be placed with the vertical centre at a height of 1.3-1.4m; except in refuges where they should be located at a height of 900mm-1.2m. They should be located where background noise is normally low.
- Our combined fire telephone/disabled refuge remote has been designed to allow appropriate mounting heights for both units. With centre of the fire telephone at 1.3-1.4m, the refuge remote is at a height of 1.1-1.2m).
- Within a sports, or similar, venue no-one should have to travel more than 30m to reach the nearest outstation.

SYSTEM REQUIREMENTS:

- Fire rated enhanced four core, colour coded, cable with a screen must be used for fire fighting systems.
- Standard fire resisting cables could be considered suitable for:
 - EVC systems for use in disabled refuges but not for fire-fighting in (a) sprinklered buildings; (b) unsprinklered buildings less than 30m in height, provided that evacuation takes place in three or fewer phases.
 - Underground sections of cabling at sports and similar venues.

ROUTINE MAINTENANCE:

We can provide routine maintenance services for all of our systems. Please refer to separate leaflet for information.

TYPICAL SYSTEM AND NETWORKING SOLUTIONS:

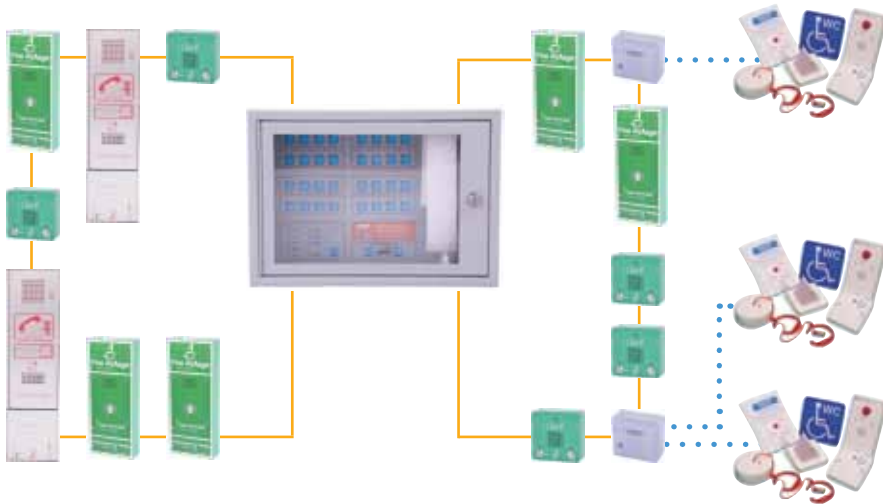

- Typical system - placing any type of remote on a single loop.
- Typically 20-30 remotes per single loop.
- Disabled toilet alarms connected to OmniCare system via a repeater unit (BVFREPEM).
- Any number of disabled toilet alarms can be connected per repeater, however, they will show as one call point on the master control panel.

KEY:

- Enhanced 4-core fire rated cable.
- 4-core security cable (not fire rated).

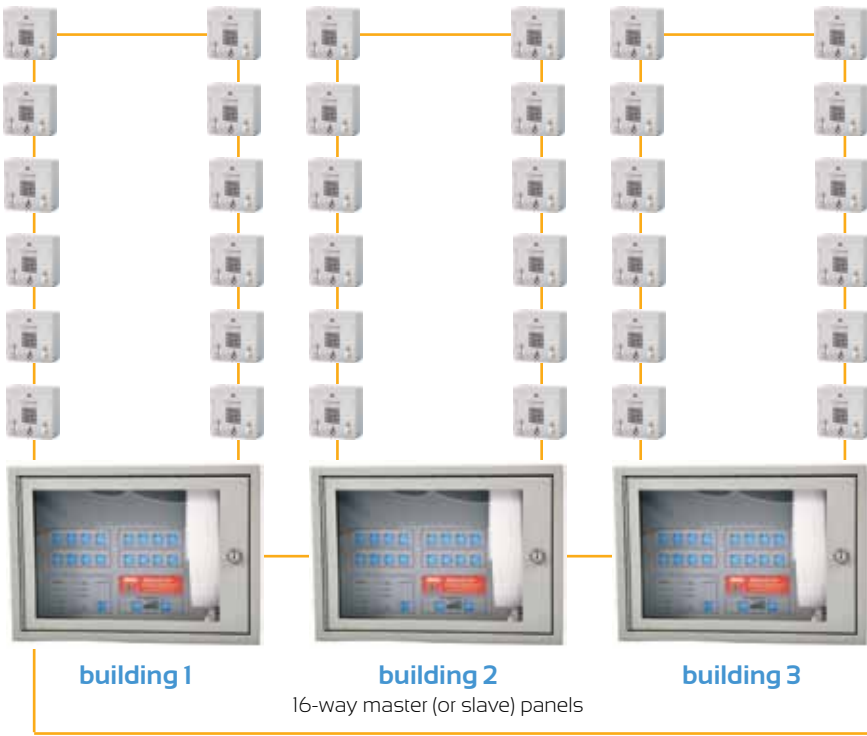

- Typical network system, providing both local control or complete system control from 'gatehouse' master panel.

BALDWIN BOXALL

TEL: +44 (0) 1892 664422
 FAX: +44 (0) 1892 663146

EMAIL: MAIL@BALDWINBOXALL.CO.UK
 WEB: WWW.BALDWINBOXALL.CO.UK

BALDWIN BOXALL COMMUNICATIONS LTD
 WEALDEN INDUSTRIAL ESTATE,
 FARNINGHAM ROAD, CROWBOROUGH,
 EAST SUSSEX, TN6 2JR, UNITED KINGDOM.



WE RESERVE THE RIGHT TO CHANGE THE PRODUCT SPECIFICATION WITHOUT PRIOR NOTICE OR LIABILITY. DOC NO. 1.0013.0311

EMERGENCY VOICE COMMUNICATION MOUNTING HEIGHTS

This document outlines the specified mounting heights for master control panels and outstations in an emergency voice communication (EVC) system. The information is extracted from BS5839-9:2011 and BS8300:2000.

CONTROL PANEL:

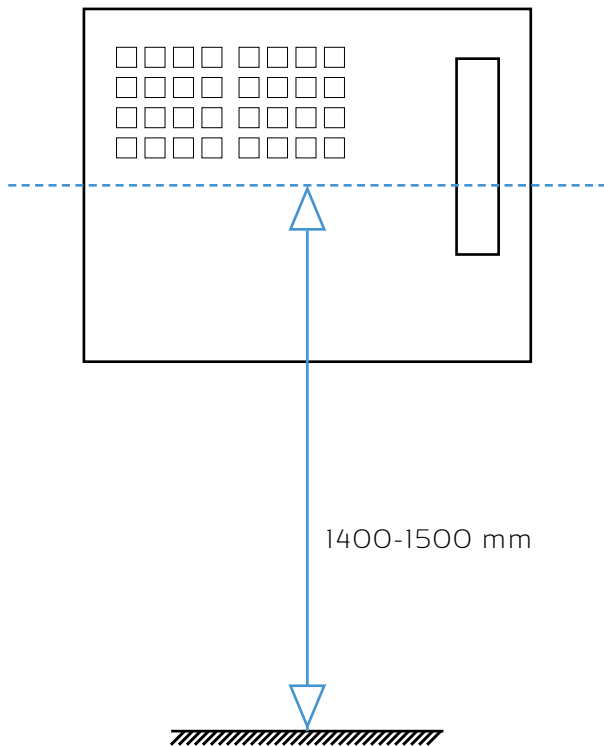

REMOTE UNITS - IN REFUGE AREAS:

Typically disabled refuge remotes:

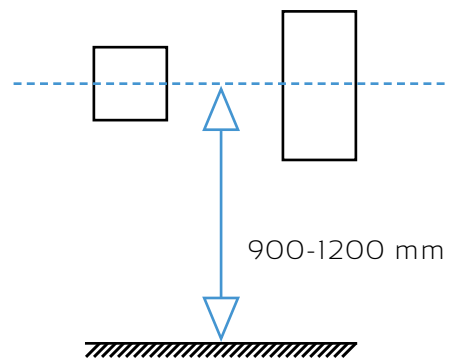

Combined remote:

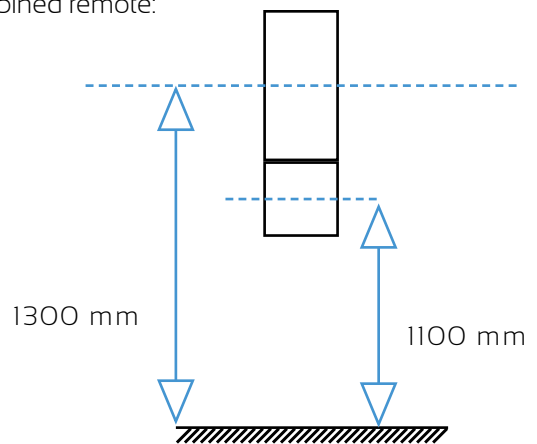

DISABLED TOILET ALARM PULL CORD:

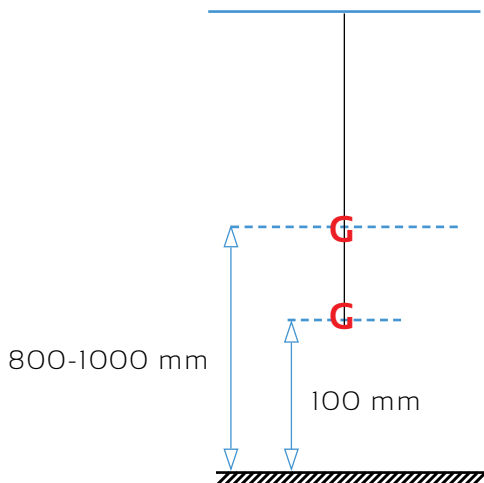

REMOTE UNITS:

Typically fire telephones & steward telephones:

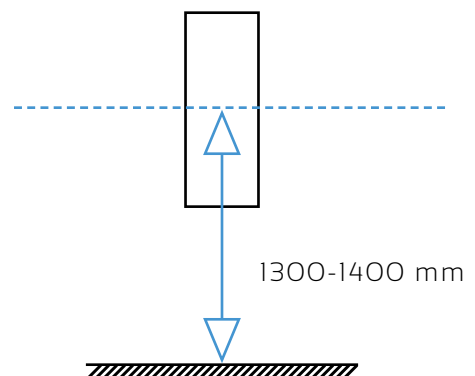

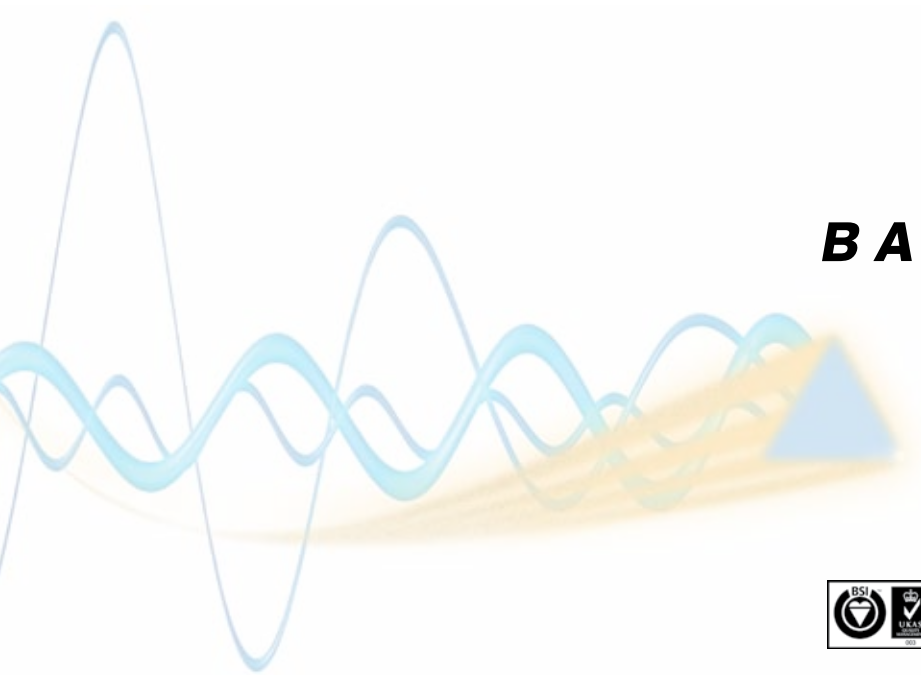

BALDWIN BOX▲LL

TEL: +44 (0) 1892 664422
FAX: +44 (0) 1892 663146

EMAIL: MAIL@BALDWINBOXALL.CO.UK
WEB: WWW.BALDWINBOXALL.CO.UK

BALDWIN BOXALL COMMUNICATIONS LTD
WEALDEN INDUSTRIAL ESTATE,
FARNINGHAM ROAD, CROWBOROUGH,
EAST SUSSEX, TN6 2JR, UNITED KINGDOM.



WE RESERVE THE RIGHT TO CHANGE THE PRODUCT SPECIFICATION WITHOUT PRIOR NOTICE OR LIABILITY.



EMERGENCY VOICE COMMUNICATIONS PRODUCT CODES

VIGIL *OmniCare*

OmniCare is an addressable voice communication system that allows disabled refuge, fire telephones, emergency/steward telephones and disabled toilet alarms to be connected to one master control panel. VIGIL OmniCare has been designed and built to meet BS9999:2008, BS5839-9:2011 and BS8300:2009 (for the disabled toilet alarm).

Individual leaflets are available which explain the OmniCare system in detail (master control panels, remote units, disabled toilet alarm, wiring & networking and relevant British Standards). For copies of these leaflets please contact: mail@baldwinboxall.co.uk.

For assistance with system design or if you would like to discuss your requirements, please contact our Sales Department: 01892 664422.

MASTER CONTROL PANELS:

Description		Product code	Bezel	Rack Mount Kit	Spare Key
Mini 410mm W x 290mm H x 200mm D	4-way	BVOC4M	BVCRFB2	BVCRM3	KEYBVE
	8-way	BVOC8M			
	16-way	BVOC16M			
	32-way	BVOC32M			
Mini - Stainless Steel	8-way	BVOC8MS	BVCRFB2S	n/a	
	16-way	BVOC16MS			
	32-way	BVOC32MS			
Standard 410mm W x 455mm H x 200mm D	48-way	BVOC48	BVCRFB1	BVCRM1	
	64-way	BVOC64			
Standard - Stainless Steel	48-way	BVOC48S	BVCRFB1S	n/a	
	64-way	BVOC64S			
Large 410mm W x 777mm H x 200mm D	80-way	BVOC80	BVCRFB3	BVCRM2	
	96-way	BVOC96			
	112-way	BVOC112			
	128-way	BVOC128			
Large - Stainless Steel	80-way	BVOC80S	BVCRFB3S	n/a	
	96-way	BVOC96S			
	112-way	BVOC112S			
	128-way	BVOC128S			

DISABLED REFUGE REMOTES:

Description	Product Code	Bezel	Spare Key
Standard Green	BVOCECPG	BVCRMGRN	KEYBVR
Standard Red	BVOCECP	BVCRMRED	KEYBVR
Standard Stainless Steel	BVOCECPS	BVCRMSS	KEYBVR
Advance Green - Surface Mount	BVOCAS	n/a	n/a
Advance Green - Flush Mount	BVOCAF	n/a	n/a

FIRE TELEPHONE & COMBINED FIRE TELEPHONE/DISABLED REFUGE:

Description	Product Code	Bezel	Combined with DRS remote product code (bezel)
Red, push door	BVOCF	BVFHBEZ	BVOCC (BVOCFBR)
Red, push door with beacon	BVOCFB	n/a	BVOCCB
Red, locking door	BVOCFL	BVFHBEZ	BVOCC (BVOCFBR)
Red, locking door with beacon	BVOCFLB	n/a	BVOCCB
Stainless steel, push door	BVOCFS	BVFHBEZSS	BVOCCSP (BVOCFBS)
Stainless steel, locking door	BVOCFSL	BVFHBEZSS	BVOCCSL

EMERGENCY / STEWARD TELEPHONES:

Description	Product Code	Bezel
Green, push door	BVOCET	BVOCETBZ
Green, push door with beacon	BVOCETB	n/a
Green, locking door	BVOCETL	BVOCETBZ
Green, locking door with beacon	BVOCETLB	n/a

DISABLED TOILET ALARMS:

Description	Product Code
Standard kit	BVOCDTA
Stainless steel kit V1	BVOCDTAS
Stainless steel kit V2	BVOCDTAS2
Additional pull cord	BVOCCSS
Additional pull cord (stainless steel)	BVOCCSS2
Slave reset point	CRP
Slave reset point (stainless steel)	CRPS

SUNDRY ITEMS:

Description	Product Code
Plasterboard backbox & bezel for BVOCECPG	BVCRFBG
Plasterboard backbox & bezel for BVOCECP	BVCRFBR
Plasterboard backbox & bezel for BVOCECPS	BVCRFBS
Repeater unit - Zintec finish	BVFREPEM
IP66 enclosure for BVOCECP/G	BVCRIPBG
Remote lamp/buzzer for master panel switch contact	BVOCCA

SELF-ADHESIVE, VINYL LABELS:

Description	Product Code
'Refuge Point'	BVOCLAB1
'These premises.....' *	BVOCLAB2
'Keep clear..Refuge..'	BVOCLAB3

* A BVOCLAB2 is supplied with each master panel.

BALDWIN BOXALL

TEL: +44 (0) 1892 664422
FAX: +44 (0) 1892 663146

EMAIL: MAIL@BALDWINBOXALL.CO.UK
WEB: WWW.BALDWINBOXALL.CO.UK

BALDWIN BOXALL COMMUNICATIONS LTD
WEALDEN INDUSTRIAL ESTATE,
FARNINGHAM ROAD, CROWBOROUGH,
EAST SUSSEX, TN6 2JR, UNITED KINGDOM.



WE RESERVE THE RIGHT TO CHANGE THE PRODUCT SPECIFICATION WITHOUT PRIOR NOTICE OR LIABILITY. DOC NO. 100140311



EMERGENCY VOICE COMMUNICATIONS BRITISH STANDARDS

VIGIL OmniCare

CARE 2

Our CARE2 and VIGIL OmniCare ranges have been designed and built to meet relevant British Standards. There are some disciplines within these Standards which we would like to point out to you and are covered in this leaflet. The British Standards are:

BS9999:2008

BS5839-9:2011

BS8300:2009

BS9999:2008 - EXPLAINED:

Code of practice for fire safety in the design, management and use of buildings. (BS9999:2008 supersedes BS5588-8).

- Definition 'Refuge' - a place of relative safety. It should be protected from a fire for a period of time sufficient to enable safe evacuation. A temporary waiting area where disabled people can await evacuation.
- Refuge areas need to be provided on all storeys (except where there is a level access to a final exit). They should be provided for:
 - Each protected stairway affording egress from each storey, and
 - Each final exit leading onto a flight of stairs external to the building.
- The minimum space for a refuge needs to be at least 900mm x 1400mm, as it needs to be of sufficient size to allow a wheelchair to manoeuvre.
- The 'door' width to a refuge should have a minimum clear opening of 850mm and the corridor width should not be less than 900mm.
- Where it is reasonably foreseeable that the proportion of disabled will be relatively high, consideration should be given to increasing the size and/or number of refuges accordingly.
- Examples of satisfactory refuges:
 - An enclosure such as a compartment, protected lobby, protected corridor or protected stairway.
 - An area in the open air such as a flat roof, balcony, podium or similar place sufficiently protected (or remote) from any fire risk and provided with its own means of escape.
- All refuges must have a minimum of 30 minutes fire-resisting separation and a FD30S type fire door.
- It is essential that the location of refuges, and of wheelchair spaces within refuges, does not have any adverse effect on the means of escape provided in the building.
- When the number and locations of refuges have been decided the essential requirement for independent communication between the occupants and evacuation management personnel need to be met.
- People in each refuge need to be assured that their presence is known to the building management. To address this there needs to be:
 - A system of two-way communication between those people.
 - The two-way communication system needs to be readily operated and comprehensible to all persons likely to need to use it.
 - The system should conform to BS5839-9:2011 and consist of Type B outstations which communicate with a master station located in the building control room or other suitable control point at fire and rescue service access level.

BS5839-9:2011 EXPLAINED:

Fire detection and fire alarm systems for buildings - Code of practice for the design, installation, commissioning and maintenance of emergency voice communication systems.

- The Standard provides guidelines for use of emergency voice communication (EVC) system in an emergency situation and for the communication with disabled persons.
- Definition 'Refuge' - an area that is enclosed with fire-resisting construction (other than any part that is an external wall of a building) and served directly by a safe route to a storey exit, evacuation lift or final exit. Thus constituting a temporary safe space for disabled people to await assistance for their evacuation.
- Type B outstations should be operated by use of a single call button.
- An outstation should be used as follows:
 - An outstation intended for evacuation or fire fighting should be Type A (Baldwin Boxall's fire telephone/emergency telephone).
 - An outstation used by the disabled should typically be Type B (Baldwin Boxall's disabled refuge/advance disabled refuge remotes).

General:

- EVC systems are generally needed in the following situations:
 - Buildings/venues where there are people who may have difficulty self-evacuating in an emergency.
 - Buildings with phased evacuation.
 - Buildings without phased evacuation but where size/type/shape necessitates communication between locations and to facilitate evacuation/firefighting.
 - Sports venues, or similar, where stewards may need to control an evacuation.
- Intended uses for an EVC:
 - Use by the management of the building or complex, for its initial evacuation.
 - Use by the fire service during an evacuation.
 - Use by the fire service after an evacuation.
 - Use by disabled people.
 - As a listen in device.
- In areas of high ambient noise, the outstation units should be supplemented with a visual warning signal i.e. beacon.
- Type A outstations should either have a door or removable front panel.
- Outstations should be capable of flush mounting.
- Outstations intended for fire fighting should be red in colour. Outstations intended for refuge communication by disabled people should be green in colour (or indicated by means of a green sign).
- In sports venues outstations should be lockable.
- Outstations in refuges should be readily available at all times and not be locked.
- In a sports venue (or similar) no-one should have to travel more than 30m to reach the nearest outstation.
- In general outstations should be placed at a height of 1.3m to 1.4m except in refuges where they should be located at a height of 900mm to 1.2m.

Outstations:

- There should be two types of outstation available:
 - Type A - an outstation using a telephone handset for voice communication.
 - Type B - an outstation using an intercom and normally mounted on a wall.
- Opening the door, or lifting the handset, in a Type A outstation should initiate the call.

Master control units:

- The master control unit should be wall mounting and have the option to be flush mountable.
- The master control unit should have a lockable door (or key switch) when not mounted in a control room.
- The master control unit should have its vertical centre of the controls mounted at height of 1.4m to 1.5m and it should be installed in an area of low fire risk.



BS5839-9:2011 continued:

System & cabling:

- Master control units and outstations should have a minimum of IP30 protection for mounting indoors.
- All interconnecting cabling should be monitored.
- An EVC system should be fully monitored and faults reported back to the master control.
- All controls on an EVC system should be clearly labelled.
- In the event of power failure the EVC should have sufficient battery backup to maintain the system for 24 hours in quiescent state followed by three hours of use in an emergency.
- Fire rated enhanced four core, colour coded, cable with a screen must be used for fire fighting systems.
- Standard fire resisting cables could be considered for:
 - EVC systems for use in disabled refuges but not for fire fighting in (a) sprinklered buildings; (b) unsprinklered buildings less than 30m in height, provided that evacuation takes place in three or fewer phases.
 - Underground sections of cabling at sports and similar venues.
- An EVC system should be regularly inspected and serviced by a competent person with specialist knowledge.

CARE2 AND VIGIL OMNICARE COMPLY TO BS9999:2008 AND BS5839-9:2011 WHEN INSTALLED CORRECTLY.



BS8300:2009 SUMMARY:

Design of buildings and their approaches to meet the needs of disabled people. Code of practice on accessible buildings.

- A disabled toilet alarm must not be confused, visually or audibly, with a fire alarm.
- The alarm pull cord should be sited so that it can be operated from the toilet and adjacent floor area.
- The pull cord, coloured red, should provide two red bangles of 50mm diameter - one set at 800-1000mm and the other set at 100mm above floor level.
- Visual and audible feedback should be provided to indicate the alarm has been triggered.
- The alarm indicator located outside the toilet area should be placed where it will be seen and heard by people able to provide assistance and indicate where help is required.
- An additional alarm indicator may be fitted remotely.
- The reset control must be clearly marked as such and sited so that it is within reach from a wheelchair and the toilet.

BALDWIN BOXALL'S DISABLED TOILET ALARM COMPLIES TO BS8300:2009 WHEN INSTALLED CORRECTLY.

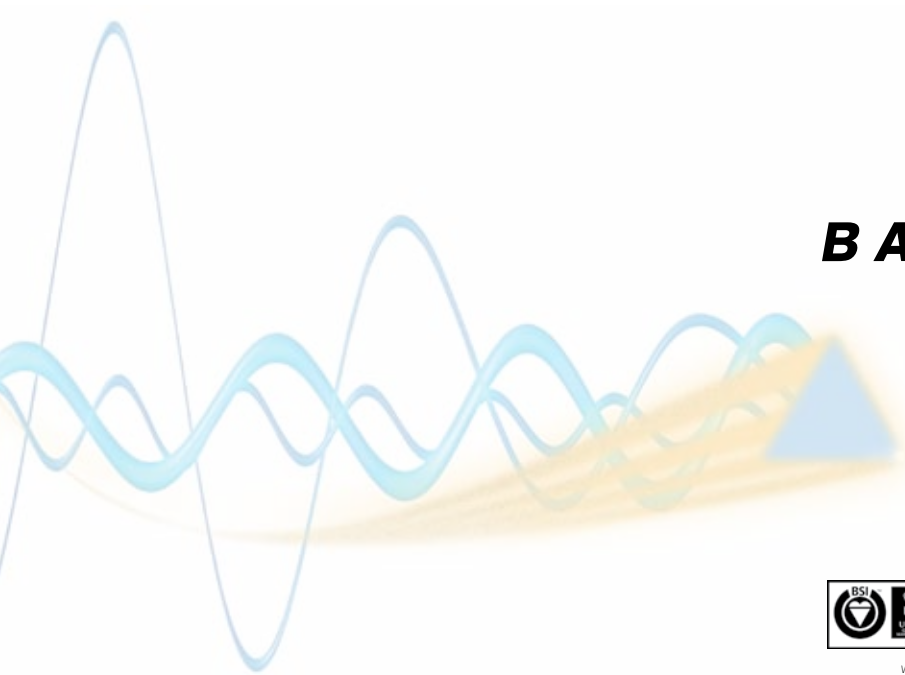

BALDWIN BOX▲LL

TEL: +44 (0) 1892 664422
FAX: +44 (0) 1892 663146

EMAIL: MAIL@BALDWINBOXALL.CO.UK
WEB: WWW.BALDWINBOXALL.CO.UK

BALDWIN BOXALL COMMUNICATIONS LTD
WEALDEN INDUSTRIAL ESTATE,
FARNINGHAM ROAD, CROWBOROUGH,
EAST SUSSEX, TN6 2JR, UNITED KINGDOM.



WE RESERVE THE RIGHT TO CHANGE THE PRODUCT SPECIFICATION WITHOUT PRIOR NOTICE OR LIABILITY. DOC NO: 1.0015.0312